

**KRYSTEL KLEER
WASTEWATER TREATMENT
PLANT
Model ADV 5000
Advanced System
Owners Manual
2010 V. 1**



It is the responsibility of the property owner
To advise **Krystel Kleer**, your service provider,
On 07)33 827666 of your contact number, house number and name
So your system can be maintained.

CONTENTS

	Page
Cover page	1
Contents	2
Notice	3
Foreword	4
Electrical Specifications	5
Delivery & Installation Instructions	6
Owners Responsibility before system can be commissioned	7
Site Preparation	8
Plants List	9
Irrigation area Council Requirements	10
Process Flow & General Description	11
Helpful Hints	12
Fault Finding	13
Very Important Notice	14
Maintenance	15
Responsibilities and Legal Requirements	16
Responsibility	17
Garden Irrigation	17
House Keeping / Plumbing Problems	18
Warranty	19
Change of Ownership	20
Service Centres	20

NOTICE

The information in this Handbook is provided as a guide only, should you require more detailed information in relation to the operation of your new Wastewater Treatment Plant please don't hesitate to contact our customer service department during office hours.

Quality Tanks (Qld) Pty Ltd (the designers and manufactures' of the "Krystel Kleer" Wastewater Treatment Plant) strive to continually improve their products so please be aware that the contents of this Handbook may change without notice.

Regulations vary from State to State, dependent on conditions prevailing in each State. You are requested to check details with the relevant authorities or contact our Customer Service Department for advice.

Each installation of a Krystel Kleer Wastewater Treatment is site specific and no relation can be formed with other installations in your area. Site and Soil Evaluations are a requirement and have to be submitted to the Local Council for approval before a Treatment Plant can be installed on your property.

It is the responsibility of the owner to keep the Treatment Plant serviced at all times as per local Council requirements. This servicing must be carried out by accredited service personnel.

Please visit our Website: www.qualitytanks.com.au for up to date information in relation to our products.

FOREWARD

Dear Customer,

KRYSTEL KLEER Model ADV 5000 (Ten Person Capacity/Nitrate Reduction)

The Krystel Kleer is one of the most advanced Aerated Wastewater Treatment Systems available in Australia today. The Krystel Kleer will produce an effluent quality that is approved by Building Codes of Queensland and meets with the requirements of the Queensland Plumbing & Wastewater Code. The quality of the effluent is so good that it will assist in reducing size of costly irrigation areas in most States in Australia. The Krystel Kleer Wastewater Treatment Plant is very suitable for small blocks and properties that have environmental concerns such as water course, dams etc.

KRYSTEL KLEER – The Krystel Kleer Wastewater Treatment Plant has undergone a strict 26 week test regime to insure that it performs with in the Building Codes of Queensland accepted guide lines. You can be confident that the Krystel Kleer is a tested system that produces a quality of treated effluent that reduces the bacterial levels well within what the regulating authorities consider safe in the new accreditation guidelines.

QUALITY TANKS (QLD) PTY LTD – Responsible for the development of the Krystel Kleer systems are now producing Wastewater systems that in the future will be used as the alternate to sewer, septic tanks, and costly pump-outs. Not only is the Krystel Kleer System superior in its reduction of bacteria and environmentally friendly by removing a high proportion of nitrogen in the treated effluent thus protecting our native shrubs and trees.

This handbook has been produced to assist your understanding of the Krystel Kleer Wastewater Treatment Plant and should be kept in a safe place for future reference. Should you sell your home please pass on this Handbook to the new owners along with any other records that you may have in relation to the Krystel Kleer Wastewater Treatment Plant.

If you have any questions please do not hesitate to call our Customer Service Department who will assist you with your enquiry.

On behalf of Quality Tanks (Qld) Pty Ltd we thank you for your support in purchasing our product and we look forward to an ongoing relationship with you.

KEN GRAY

MANAGING DIRECTOR

ELECTRICAL CIRCUIT SPECIFICATIONS FOR KRYSTEL KLEER

Important: Please note there is no Home Owner requirement to touch any of the electrical components. Please consult a licensed electrical contractor.

Caution: this specification changes from time to time – always check.+

The conduit must be run to the junction box mounted in the side of the control box on the treatment tank. **Ensure you glue all joints in your conduit run** to prevent water from entering your conduit and the Krystel Kleer control box and causing damage. Water ingress is not covered under warranty.

- **A dedicated single phase plus earth circuit, protected by a 16 amp** MINIMUM circuit breaker of 8Ka type suitable for motor start, such as Weber/Martec AS168 type, Quicklag, Terasaki Safe “T” or Clipsal “U” type. Minimum cable size 2.5mm, Connected to and run from an EXTERNAL building switchboard (to allow for maintenance when the house is unattended), to the Krystel Kleer terminal box. Alarm wiring run can be two-core switch wire.

Circuits should be labelled “Krystel Kleer System”

The above circuits must be connected to the terminals as labelled in the Krystel Kleer terminal box.

Note: Electrical work must be carried out in accordance with A.S/N.Z. 3000 and Supply Authority Rules. A “Notification of electrical work” certificate must be lodged with the Supply Authority for your wiring.

Continuous running current is 0.6amp with maximum intermittent current up to 3.1 amps (dependant on submersible pump size).

Upon initial energizing of the circuit to the system, the alarm may sound. This may be caused by high water level, and is no cause for concern. If the power is left on, the level will return to normal within 30 minutes and the alarm will automatically reset. Be sure to return the alarm to “NORMAL” after the alarm has reset.

Alarm Panel: If the alarm panel is more than 30 meters away from the Krystel Kleer control box use shielded cable for **SW to alarm panel** to avoid any induced voltage from active cable.

Fault Conditions

- Yellow light and buzzer low air pressure. Red light and buzzer high water, both lights U.V. light problem.

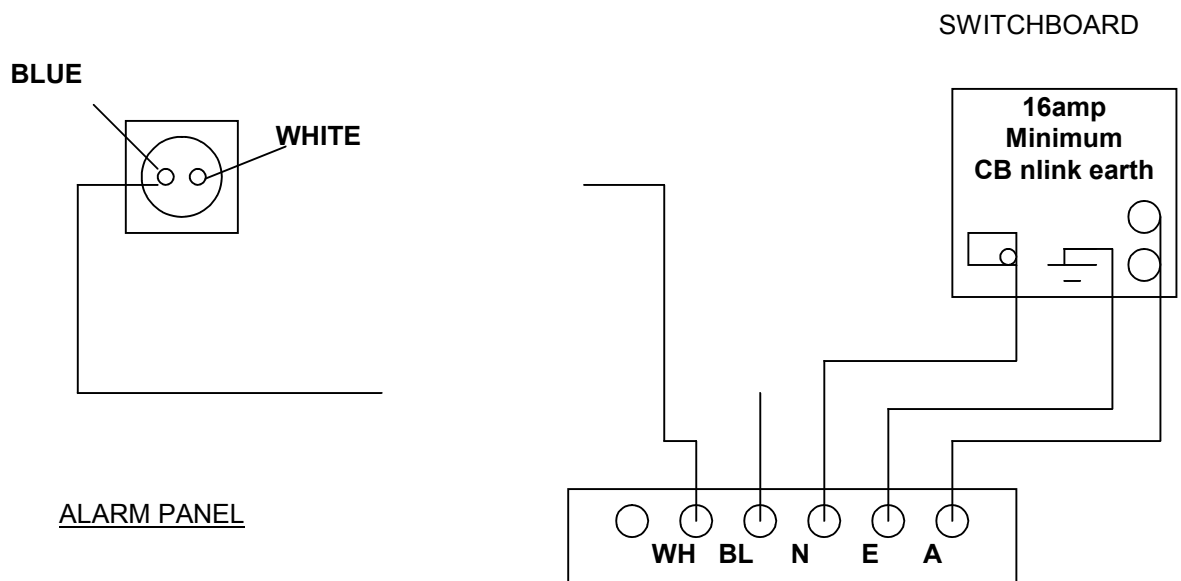

WIRING DIAGRAM

DELIVERY AND INSTALLATION INSTRUCTIONS

KRYSTEL KLEER

- In most areas tanks will be delivered by a truck equipped with a crane located at the rear of the vehicle. Such vehicles will back up to the tank site, lift and slew the tank into position behind the vehicle before placing it into the prepared hole. Maximum reach from the rear of the vehicle is 3M to centre of tank.

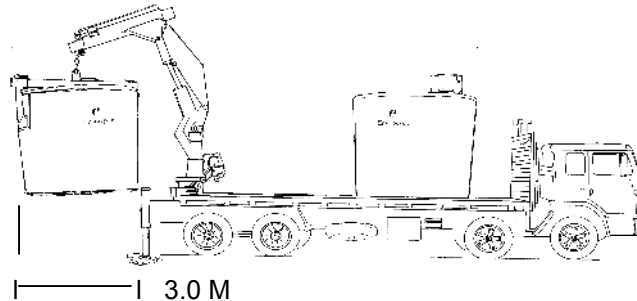

- Make sure the truck has access to your site and observe the following requirements:
 - 4.8m needed to pass under trees and power lines.
 - 3.0m needed between gateposts.
 - Site conditions should be dry and stable under foot.
- To enable the tank to be unloaded, a distance of 6m will be required.

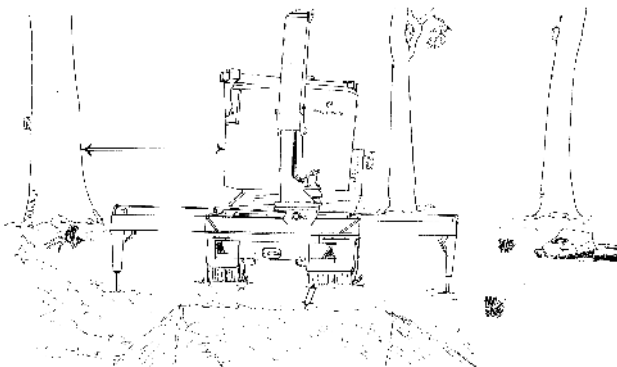

That is: 2.44m of truck
2.48m of tank
1.00m clearances

This also allows enough distance for the crane's outriggers (legs).
This diagram also applies for right-hand side unloading.

- Tanks will not be lifted over houses, sheds or other property of value, nor will they be lifted under low power lines.
- Tank sites that are cut out of slopping hills will require enough flat area for the truck to unload.

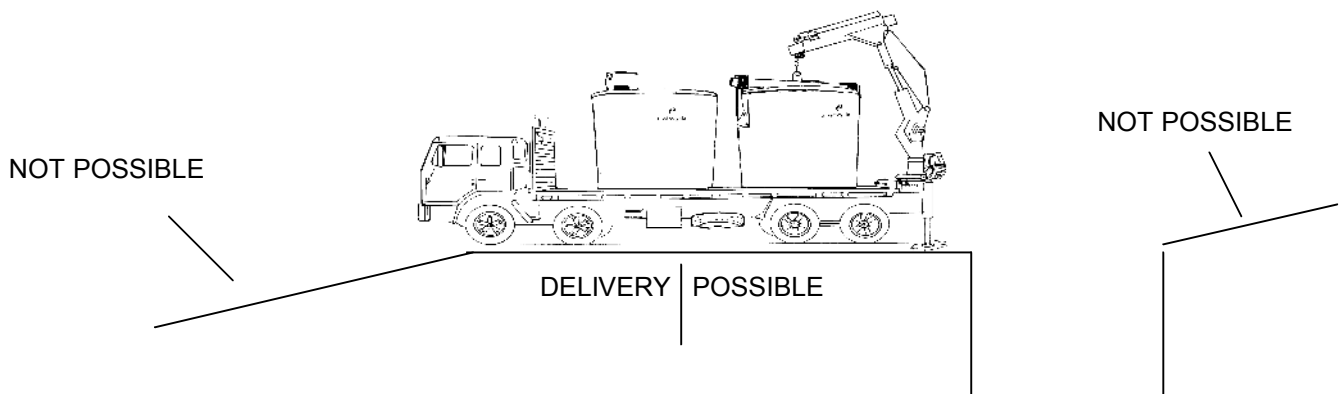

Unloading on awkward and dangerous sites will be at the driver's discretion. Safe and clear access is total responsibility of the customer.

Tank Dimensions

Electric box Height	0.420m
Outside Diameter	2.480m
Overall Height	2.110m
Height to 100mm inlet	1.637m

(Measured from tank bottom to bottom inlet pipe)

7. Backfill – Use sand or excavated material/spoil with maximum particle size of 50mm. Ensure that sand or excavated material does not fall on the lid of the tank, as this will fall into the system through the manholes and clog the system and irrigation pump. Ensure that the backfill material is kept at least 150mm below the surface of the tank lid.

8. Organise electrical and drainage contractor to connect the Krystel Kleer system to services.

9. The electrical contractor must follow the electrical specification supplied with the Krystel Kleer alarm panel at the time of delivery.

10. The drainage connection is a standard 100mm sewer inlet.

11. Commission – The Krystel Kleer Treatment Plant is ready for commissioning once the electrical power is provided to the system.

IMPORTANT: THE SYSTEM CANNOT BE COMMISSIONED UNLESS POWER IS AVAILABLE AT THE UNIT.

12. Commissioning Checklist-

PLEASE ENSURE THE FOLLOWING IS COMPLETED PRIOR TO COMMISSIONING.

Owners Responsibility

- Krystel Kleer Treatment Plant is filled with 5300 litres or to a depth of 1300mm in Primary Chamber (first chamber) of portable water.
- Irrigation area is completed.
- Irrigation line is available at tank.
- Electrical power is connected.
- Drains connected.

13. The Krystel Kleer system will then be switched on (Commissioned) by an accredited technician employed/or an agent of Quality Tanks (Qld) Pty Ltd.

14. Site preparation drawings shows excavation walls to be perpendicular. However, depending on soil conditions, the excavator may need to angle or retain the sidewalls such that they don't cave in during installation.

15. Except for the person/s responsible for lifting and positioning of the tank in the excavated site, there must not be any person within 20m of the installation site during lifting and positioning of the tank.

16. Tank must be level in both inflow/outflow direction and 90o to the inflow/outflow direction (< 1o deviation).

Note: Do not act solely on the basis of the material contained above. Items herein are general comments only and do not convey advice per se. We therefore recommend that our formal advice be sought before acting in any of these areas.

SITE PREPARATION – KRYSTEL KLEER TREATMENT PLANT

FLAT SITE - HOLE TO BE DUG TO THE FOLLOWING DIMENSIONS

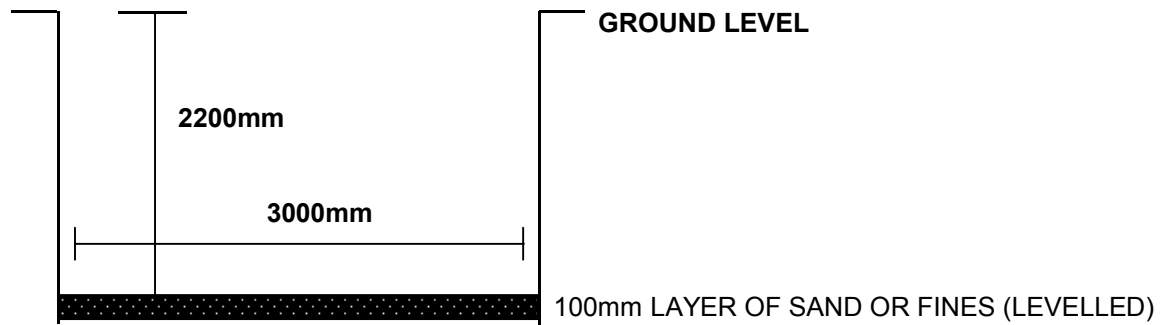

The base of the septic tank should be placed on 100mm layer of sand or fines. To this an area of 3 Metres Square should be dug to a depth of 2200mm below ground level.

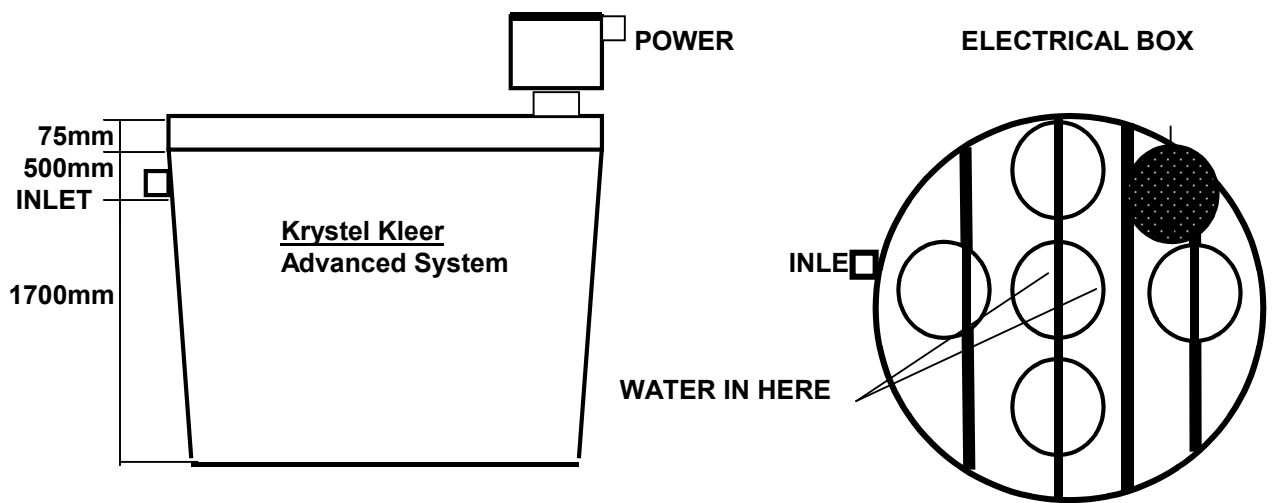

IMPORTANT: AFTER INSTALLING, FILL TANK WITH 5300 LITRES OR TILL BOTH LOTS OF MESH ARE COVERED EACH SIDE OF CENTRE PANEL, PLEASE USE POTABLE WATER **Note:** If tank is not filled with water it could hydraulically lift out of the ground during wet conditions. Water is also required in order for the Krystel Kleer system to be commissioned.

Filling the tank with water should be done by the installer and the company will not accept any responsibility if this action is not carried out.

Excavation drawing shows excavation walls to be perpendicular. However, depending on soil conditions, the excavator may need to angle and/or retain the side walls such that they don't cave in before the tanks are installed.

Do not act solely on the basis of material contained above. Items herein are general comments only and do not convey advice per se. We therefore recommend that our formal advice be sought before acting in any of these areas.

SUITABLE PLANTS FOR THE SURFACE **IRRIGATION AREA**

NOTE: The list is only intended to provide a selection of trees, shrubs and other plants which may be considered suitable for the surface irrigation disposal area. However, because of wide climate and soil variations it is essential that further investigation be made with your local plant nursery before finalising your plant choice to suit your particular locality and site conditions.

COMMON NAME

APPROX HEIGHT

TREES

Willow Myrtle	5-6 M
Cootamundra Wattle	3-6 M
River She Oak	6-10 M
Red Bottlebrush	3-6 M
Sydney Blue Gum	15-20 M
River Red Gum	15-20 M
Native Frangipani	3-5 M
Coast Tea Tree	5-6 M
Broad Paperbark	5-7 M

SHRUBS

Gossamer Wattle	2-4 M
Flinders Range Wattle	2-3 M
Umbrella Grass	1-5 M
Geraldton Wax	

CLIMBERS

Purple Coral Pea
Snake Vine
Jasminum Grandiflorum
Common Jasmin
Duskey Coral Pea
Japanese Honey Suckle

PERENNIALS

Marguerite Daisy
Shasta Daisy
Black Eyed Susan

IRRIGATION AREA COUNCIL REQUIREMENTS

System	Recommended Buffer Distances
All land and application systems	<ul style="list-style-type: none"> • 10 metres to permanent surface waters. (eg river, streams etc) • 10 metres to domestic groundwater well. • 10 meters to other waters (eg farm dams, drainage channels).
Surface spray irrigation	<ul style="list-style-type: none"> • 2 metres if area up-gradient and 4 metres if area down-gradient of driveways and property boundaries. • 10 metres to dwellings. • 2 metres to paths and walkways. • 6 metres to swimming pools.
Surface drip and trickle irrigation	<ul style="list-style-type: none"> • 4 metres if area down-gradient and 3 metres if area down-gradient of swimming pools, property boundaries, driveways & buildings.
Subsurface irrigation	<ul style="list-style-type: none"> • 4 metres if area down-gradient and 3 metres if area down-gradient of swimming pools, property boundaries, driveways & buildings.
Absorption system	<ul style="list-style-type: none"> • 4 metres if area up-gradient and 4 metres if area down-gradient of property boundary. • 6 metres if area down-gradient and 4 metres if area down-gradient of swimming pools, driveways and buildings.

Please Note: Most councils require a Site & Soil Evaluation to be carried out prior to lodging an application. Once you have moved into your home you may want to move your spray or subsurface irrigation to make way for sheds, pools etc, before doing so please consult with your local Council.

For more information contact your local council or wastewater treatment installer.

PROCESS FLOW

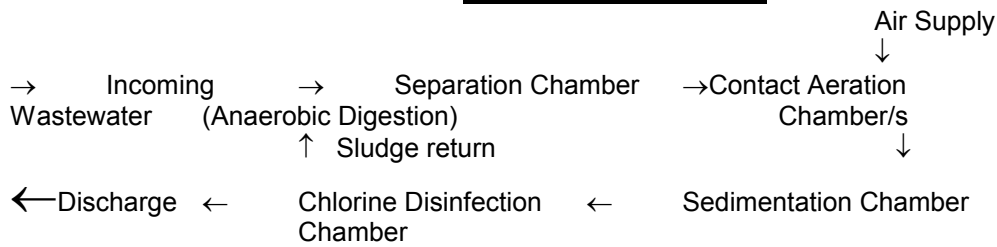

GENERAL DESCRIPTION AND FUNCTION OF THE PLANT

PRIMARY TREATMENT

The first stage of treatment is to separate the solids from the liquids. The solids mainly Toilet wastes remain in the first compartment where a digestion process takes place. The digestion is accelerated by the presence of anaerobic micro-organisms which multiply rapidly under ideal conditions and which will ensure that the offensive faecal solids are turned into an inert waste. **Hence, the microbial action in the first tank should not be hindered by the discharge of chemicals through household drainage fittings, e.g. chemical toilet cleaners and other anti-bacterial cleaning products.**

SECONDARY TREATMENT

The subsequent treatment stages are mainly concerned with the aeration of the liquid wastes. Once more microbes present in these liquids are used to assist in the aeration process. The micro-organisms are called aerobes and will thrive and multiply in the presence of oxygen. It is therefore important that a constant air supply is being maintained at all times. The air is supplied from a small blower located near the system.

SETTLING

Following aeration the liquid wastes are allowed to settle under quiescent conditions. Any solid particles, which are suspended in the aerated effluent, will settle out and are returned automatically to the first or second treatment stage. The clarified water, although it looks reasonably clean, may still contain some bacteria which will have to be removed.

TERTIARY TREATMENT

The bacteria are removed by a Chlorine process. While the clarified effluent flows through the chlorine chamber it comes into contact with a disinfecting agent. Chlorine disinfection will ensure the final effluent, meets the criteria set by regulating bodies, prior to irrigation onto your garden.

NUTRIENT REDUCTION

The aerated, clarified and disinfected water contains natural nutrients such as phosphates and nitrates, which are a bonus for the garden. Plants will readily take up these nutrients and thrive, thus completing the cycle. The Krystel Kleer Plant reduces the nitrate concentration with its process a further 75%.

OPERATION

Once all your household drainage fittings have been connected correctly to the unit, it can be used for its intended purpose immediately; provided your irrigation area has been landscaped to the satisfaction of your local Council.

The landscaping requirements are very essential, because you cannot irrigate on barren dirt. The entire operation of the Krystel Kleer is automatic.

Please refrain from making any adjustments to the air supply or pumping equipment.

Should you require further information on the operation of the system, please contact the nearest Krystel Kleer office and speak with our trained personal who will discuss your needs with you.

GENERAL

1. Electricity Consumption - Our electrical consultants advise that the annual usage of electricity for the total system is similar to an average household refrigerator. Please don't turn your Treatment Plant off to save power, this will only result in damage to the system.

2. Septic Tank/Compartment - Dependant on individual household usage, it will be necessary to periodically remove the contents. This is the homeowner's responsibility. Our company will assist where required but with costs for customers account. This service may be carried out by any person or organisation approved by the Health Department.

3.

HELPFUL HINTS

Hereunder are recommendations to maintain performance of your system within standards set by the regulating bodies. With a little care you will have trouble-free use for a long time.

- AVOID** - Disposing of newspaper, disposable or sanitary napkins.
- The use of garbage disposal units in sinks.
- DO NOT** - Use strong caustic, alkalis, oils, acids, bleaches, disinfectants or chemical detergents. These items kill the purifying bacteria, cause bad odours and damage the workings of the system.
- DO NOT** - Exceed the maximum design load or subject the system to hydraulic shock loads.
- DO** - Use biodegradable detergents.
- SPREAD** - Your wash loads over six or seven days where possible.
- NEVER** - Switch off power. "Never Ever"
- CHECKLIST** - In the unlikely event of anything going wrong PLEASE DO NOT PANIC. Please refer to the faultfinding section below.
- USE** - Cleaning products that specify "Safe for Septics".
- MAINTAIN** - Your Irrigation area. Keep the lawn mowed
- RENEW** - Your Service Agreement every 12 months
- QUESTION** - If you have any problems or questions contact our service department.
- REACT** - If the alarm is activated eliminate the problem ASAP.

FAULT FINDING

Careful attention should be paid to the points mentioned on Page 5 of this handbook, for efficient plant operation.

However, on rare occasions, some minor mishaps, which can easily be rectified, do occur. Please do not panic as the plant is designed to give sufficient leeway, with normal household usage, before untreated wastewater is discharged.

FAULT - The Alarm Operates

CAUSE

1. Tripping of a circuit breaker in the control box.
2. Irrigation pump failure.
3. Blocked irrigation filter.
4. Kink in irrigation line.
5. Blockage in irrigation line.
6. Blower failure.
7. Power failure.

ACTION

- * Turn alarm to mute.
- Listen at the control box to hear if the blower is running. If not, see; **VERY IMPORTANT NOTICE** (re: instruction to reset circuit breaker).
- If blower is running check irrigation system for:-
 - a) Blocked filter (early models)
 - b) Kink in hose
 - c) Blockage in hose

FAULT - Irrigation Does Not Work

CAUSE

1. Pump failure
2. Blocked filter (early models) or blocked irrigation line.
3. Kink in hose.

ACTION

- * See **VERY IMPORTANT NOTICE** (re instruction to reset circuit breaker).
- * Clear filter or lines.
 - * Straighten hose.

FAULT - Excessive Foaming

CAUSE

1. Too much detergent being used in laundry.
2. Too many washes.

ACTION

- * Use recommended Quantities.
- * Do one or two washes per day.

FAULT - Persistent Odours

CAUSE

1. The first chamber in the system has not matured yet.
2. Too much water is being discharged through your household fittings at the same time.
3. Excessive chemicals and/or disinfectants are being used in your residence.
4. E-duct vent or S-bends are not suitably constructed.
5. Exposed areas in tanks, seal degradation.
6. The system is required to do more than it is designed for.

ACTION

- * Refer to the local office for advice.
- * Avoid using the shower and automatic washing machine at the same time.
- * Please avoid and the system will recover.
- * Refer your plumber or the local office for advice.
- * Apply a light mix of sand/cement or similar mix.
- * Refrain from overloading. Refer the local office for advice.

VERY IMPORTANT NOTICE

The use of proven high quality materials ensures long life of the plant. Our experience has however, shown that despite our best intentions, we have **no control** over the power supply to your home.

Although the circuitry allows for variances in power supply; **a power cut, substantial surge of power or voltage drop** in your area may trip the circuit breakers and trigger the early warning system supplied.

HOW TO RESET SYSTEM CIRCUIT BREAKER

Some clients may live in areas that are prone to fluctuating power supplies. On rare occasions this may cause the Krystel Kleer System to shut down, resulting in the alarm operating. The fluctuating power supply may cause the overload circuit breaker in your switchboard to trip to the 'off' position (down position). This is not a fault of the system but rather a characteristic to protect the equipment within the system.

If, after a power cut or voltage fluctuation, the Krystel Kleer system alarm does not clear itself within 12 hours, it may be necessary for you, the customer, to reset the tripped circuit breaker.

To do this, open your switchboard and look for the circuit breaker marked "Krystel Kleer" or whatever your electrician may have called it. There will be **two** circuit breakers. If one of them is in the **down** position it is **off**. To reset, lift the circuit breaker toggle to the up position. Upon doing this the blower will immediately re-start and the system will function normally.

- The alarm may take 12 hours to clear.
- Don't forget to reset the alarm to **NORMAL**.

IF THE CIRCUIT BREAKER SWITCH WILL NOT STAY UP, PLEASE CALL Krystel Kleer

REMEMBER:

THIS PROBLEM IS BEYOND OUR CONTROL.

Note: For security reasons we suggest that when on holidays you turn the alarm to **MUTE**.

On your return please revert to the ON position.

MAINTENANCE

To ensure that sewage treatment plants perform to the high standards set by the regulating bodies, a maintenance program is stipulated by these bodies in the interest of environmental health and safety. Failure to have stipulated service carried out could result in a breach of public health legislation and subsequent legal proceedings.

The following information covering the requirements and maintenance for the first, second and ensuring years of operation is provided for your guidance.

1. THE KRYSTEL KLEER PLANT (excluding the Septic Tank/Compartment, mechanical and electrical components)

Every 4 months inspections will occur during which the following are undertaken:

- Adjustments to air intake where necessary.
- Adjustments to sludge return where necessary.
- Cleaning of the plant, if necessary.
- Monitoring and maintaining the balance of the purifiers.
- Check sludge levels.
- Replenish Chlorine holders
- Tests on water quality – on site.
- Reports forward to the Local Council as directed.

BLOWER, IRRIGATION PUMP, AND ELECTRICAL COMPONENTS.

Complete servicing and maintenance check of the blower, irrigation pump, and electrical system.

AFTER SALES SERVICE: Our Company offers a range of maintenance options. Please contact the Maintenance Department for further information.

NOTE: Krystel Kleer only requires 4 services per annum.

RENEWALS

An offer to renew a maintenance program is provided after the third service in a twelve month period.

The offer is valid for thirty days.

Please choose a desired program and send your cheque, together with a signed copy of this offer, to our office. See Attached Maintenance Agreement.

Please ensure that all terms and conditions have been read and understood.

RESPONSIBILITIES AND LEGAL REQUIREMENTS

In the interest of the homeowner and the public, certain requirements are imposed by the regulating bodies with regard to the installation of sewage treatment plants; be they Krystel Kleer, Septic or other systems.

The following are provided as a guide only.
(Please check with the local regulating body for further information.)

- The Krystel Kleer Plant is to be installed in the approximate position indicated in the plan.
- The system may not be used until the site has been inspected and Council considers that the effluent and sullage can be completely disposed of on the site without nuisance or likely danger to health.
- No fruit or salad vegetable growing on the property shall be irrigated with effluent from the system.
- There shall be no irrigated water run-off from the allotment to the adjoining properties, public places or reserves.
- The operator's manual, incorporating a service record, is to be provided with the unit. The date of each service shall be entered on the record sheet.
- The owner shall enter into a service contract with the manufacturer, distributor or their agents or any firm or contractor considered to be competent by the local Council.
- The service contractor shall make adjustments to each unit, its ventilation and irrigation system, when directed to do so by the department of Health, or local Council.
- The yard or garden areas of the allotment are turfed and/or landscaped to the satisfaction of Council and the Department of Health, before the system is used for irrigation purposes.

Detailed conditions of installation are stated on the approval given to you by the regulating body. Please read them carefully and ask for advice should it be necessary.

RESPONSIBILITY

The owner of the plant is entirely responsible for the operation and maintenance of the plant.

The existence of a service contract does not transfer the responsibility from the owner to the supplier or its agents.

Quality Tanks (Qld) Pty Ltd will not accept responsibility for warranty or operation if the Krystel Kleer is not serviced regularly by an accredited technician.

GARDEN IRRIGATION

Please do not waste this water.

You should be aware of the health Authority's requirements that: 'There shall be no irrigated water run-off from your allotment to adjoining properties, public places or reserves.'

Generally speaking you are not permitted to water the Councils footpath and care should be taken not to allow any run-off onto your neighbour's land.

It is the owner's responsibility to ensure that the irrigation area/s is maintained at all times. The maintenance technician will assist as much as possible.

NOTE: During maintenance inspections by the maintenance technician a report will be forwarded to the local council on the condition of the irrigation area.

GENERAL TOPICS

ACCESS

For maintenance purposes, please ensure that FREE access is available to ALL manholes on the tank/s and to the ELECTRIC BOX. This is a requirement of the regulating.

Soil, plants, bark, etc. MUST be removed prior to a maintenance service.

BLOWER DAMAGE – A VERY COSTLY PROBLEM

Avoid this problem by creating channels to take rainwater away from the vicinity of the Electric Box.

DO NOT create a water catchment area around the Krystel Kleer system as this could flow into the Control Box and cause fusion of the Blower during periods of heavy rain.

Insurance companies will NOT reimburse you for Blower damage caused by your negligence.

HOUSEKEEPING

Irrigation lines, spray heads, etc. can clog up over extended periods of use. (Dirt etc)

Manufactures of such equipment recommend that these items be flushed at least monthly.

To avoid any inconvenience to you and to keep costs down, please comply with the manufacturers recommendations.

PLUMBING PROBLEMS

- BLOCKAGES IN THE DRAINAGE LINES from the house to the system are plumbing problems. If your household fittings are not draining away, please check the inlet to the Septic Tank or Compartment for blockages.

Usually the lines can be cleared at this INLET point by inserting a rod down the inlet pipe.

Should this not be possible please call your local plumber or drainer.

- THE LOSS OF A WATER SEAL in fittings, allowing gases to escape, should be initially referred to your local plumber for corrective measures.

AN INCORRECTLY CONSTRUCTED E Duct Vent could be the cause of this problem.

- E DUCT VENTS should be constructed to ensure the proper dispersal of gaseous by-products prevalent in all forms of sewage treatment.

The vent should be positioned at least 600mm above the highest point in the house so that prevailing winds will carry away such gases.

IN THE HOUSE

- Reduce foaming by adding a tablespoon of crushed bath soap (leftovers) to your washing powder.
- After wiping down tiles and the like, rinse the cloth in a bucket then discard the contents in the yard, not in the system.
- When the alarm sounds PLEASE refer to the fault finding section in this handbook before calling us

THIS WILL HELP KEEP DOWN COSTS

WARRANTY
KRYSTEL KLEER TREATMENT PLANT

<u>Structure</u>	<u>Warranty</u>	<u>Service Life</u>
Concrete Tank	15 years	20 years
Internal Baffles (Concrete)	15 years	20 years
 <u>Fittings</u>		
Pipework (PVC etc)	15 years	20 years
Fixings (Stainless etc)	15 years	20 years
Filter Media	15 years	20 years
 <u>Electrical Components</u>		
Control Box	1 year	5 years
Alarm Panel	1 year	5 years
Irrigation Pump	1 year	5 years
Air Pump	1 year	5 years

NOTE: Warranty is conditional upon an accredited Krystel Kleer Service technician maintaining the system continuously after commissioning.

All mechanical and electrical parts have a minimum service life of 5 years. Service life is the time for mechanical and electrical parts to operate before breakdown/failure is expected.

Air Pumps have components, which must be changed or cleaned at every service at owner's cost.

CHANGE OF OWNERSHIP

TO ENABLE US TO CONTINUE SERVICING THE SYSTEM, COULD YOU PLEASE ADVISE US SHOULD YOU SELL YOUR PROPERTY.

SERVICE CENTRES

59 Commerce Circuit

Yatala QLD 4207

PO Box 5168

Gold Coast Mail Centre

QLD 9726

For Service Enquires Call 07 33827666.